

37200B Series

RF and Microwave Vector Network Analyzers for Passive Device Measurements

Technical Data Sheet



SYSTEM DESCRIPTION

The 37200B Vector Network Analyzers are high performance tools designed to make fast and accurate S-parameter measurements of passive devices across the 22.5 MHz to 40 GHz range. These network analyzers integrate a synthesized source, S-parameter test set and tuned receiver into a single compact package that is ideal for bench-top testing. (For comprehensive measurements of active devices see the 37300A data sheets.)

Specifications for these 37200B models are detailed on the following pages:

RF Models:

Model 37211B 22.5 MHz to 3 GHz
 Model 37217B 22.5 MHz to 8.6 GHz

Microwave Models:

Model 37225B 40 MHz to 13.5 GHz
 Model 37247B 40 MHz to 20 GHz
 Model 37269B 40 MHz to 40 GHz

High throughput measurements are achieved in each model through the use of fast, 12-term error corrected sweeps, fast GPIB data transfers and an intuitive user interface. All measurement results are displayed on a large LCD color display or on an external VGA monitor.

For maximum productivity, the 37200B VNAs include as standard features:

- ✓ Fast Sweeping Synthesized Source
- ✓ Auto Reversing Test Set
- ✓ Solid-State Transfer Switch
- ✓ Four Independent Displays
- ✓ Four Channel Receiver
- ✓ Internal Hard and Floppy Disk Drives
- ✓ LRL/LRM Calibration
- ✓ Adapter Removal Calibrations
- ✓ Fast Measurement Throughput via GPIB

Each of the 37200B network analyzers are designed for easy upgradeability. Any version of the 37200B can be upgraded to accommodate new options or additional frequency ranges by ordering the appropriate upgrade kit. 37200B to 37300A upgrades are also supported.

SYSTEM PERFORMANCE

Dynamic Range:

The following table gives dynamic range in two manners.

“Receiver Dynamic Range” is defined as the ratio of the maximum signal level at Port 2 for 0.1 dB compression to the noise floor at Port 2.

“System Dynamic Range” is defined as the ratio of the power incident on Port 2 in a through line connection to the noise floor at Port 2 (forward measurements only).

In preparing the table, 10 Hz IF bandwidth and 512 averages were used in calibration and measurement.

Model	Frequency (GHz)	Max. Signal Into Port 2 (dBm)	Noise Floor (dBm)	Receiver Dynamic Range (dB)	Port 1 Power (dBm, Typical)	System Dynamic Range (dB)
37211B	0.0225	+3	-95	115	0	95
	2	+3	-98	101	0	98
	3	+3	-98	101	0	98
37217B	0.0225	+3	-95	115	0	95
	2	+3	-98	101	0	98
	8.6	+3	-98	101	0	98
37225B	0.04	+20	-70	90	0	70
	2	+3	-98	101	0	98
	13.5	+3	-98	101	0	98
37247B	0.04	+20	-70	90	0	70
	2	+3	-98	101	0	98
	20	+3	-96	99	0	96
37269B	0.04	+20	-70	90	0	70
	2	+3	-98	101	0	98
	20	+3	-95	98	-5	90
	40	+3	-93	96	-15	78

High Level Noise (typical): <0.03 dB and <0.4 degrees peak-to-peak variation in a 1 kHz IF bandwidth up to 20 GHz. <0.08 dB and <0.5 degrees peak-to-peak variation up to 40 GHz.

Measurement Throughput: Measurement times are based on a single 40 MHz to 20 GHz sweep with 10 kHz IF bandwidth (no averages) after a full 12-term calibration. Sweep times include retrace and band switch times.

Measurement Time (ms) vs. Data Points (typical)

Calibration Type	Data Points				
	3	51	101	401	1601
1 Port (3 Term)	60	250	330	960	3300
Full 2 Port	60	270	400	1000	3600

Measurement Time vs. Sweep Mode for 101 Data Points (typical)

Sweep Mode	Time (ms)
Linear	350
List	350
CW	230

Measurement Time vs. IF BW for 101 Data Points (typical)

IF Bandwidth	Time (ms)
10 kHz	350
1 kHz	530
100 Hz	1900
10 Hz	14000

Measurement Time vs. Span for 101 Data Points (typical)

Frequency Span	Time (ms)
40 MHz to 40 GHz	500
20 GHz to 40 GHz	400
10 GHz to 11 GHz	250

TEST PORT CHARACTERISTICS

Connector	Frequency (GHz)	Directivity (dB)	Source Match (dB)	Load Match (dB)	Reflection Frequency Tracking (dB)	Transmission Frequency Tracking (dB)	Isolation (dB)
GPC-7	0.0225	>52	>44	>52	±0.003	±0.004	>105
	2	>52	>44	>52	±0.003	±0.004	>115
	18	>52	>42	>52	±0.004	±0.012	>112
GPC-7 LRL Calibration	2	>60	>60	>60	±0.001	±0.001	>115
	18	>60	>60	>60	±0.001	±0.001	>112
N-Type*	0.0225	>46	>36	>46	±0.004	±0.004	>105
	2	>44	>36	>44	±0.004	±0.004	>115
	18	>40	>32	>40	±0.005	±0.012	>112
3.5mm	0.0225	>44	>40	>44	±0.005	±0.030	>105
	2	>44	>40	>44	±0.005	±0.030	>115
	20	>44	>38	>44	±0.006	±0.050	>110
	26.5	>44	>34	>44	±0.006	±0.070	>102
K	0.0225	>42	>40	>42	±0.005	±0.030	>105
	2	>42	>40	>42	±0.005	±0.050	>115
	20	>42	>38	>42	±0.006	±0.070	>110
	40	>38	>38	>38	±0.006	±0.080	>100

The specifications in the table above apply when the proper Model 34U Universal Test Port Adapters are connected, with or without phase equal insertables, to the test set ports and calibrated with the appropriate calibration kit at 23°C ±3°C using the OSL calibration method with a sliding load to achieve 12-Term error correction. (90 min warm-up time recommended)

*Standard OSL calibration, no sliding load.

MEASUREMENT CAPABILITIES

Number of Channels: Four independent measurement channels.

Parameters: S11, S21, S22, S12, or user defined combinations of a_1 , a_2 , b_1 , and b_2 . All measurements are made without the need to manually reverse the test device.

Measurement Frequency Range: Frequency range of measurement can be narrowed within the calibration range without recalibration. CW mode permits single frequency measurements, also without recalibration. In addition, the system accepts N discrete frequency points where $2 < N < 1601$.

Domains: Frequency Domain, CW Draw, and optional High Speed Time (Distance) Domain.

Formats: Log Magnitude, Phase, Log Magnitude and Phase, Smith Chart (Impedance), Smith Chart (Admittance), Linear Polar, Log Polar, Group Delay, Linear Magnitude, Linear Magnitude and Phase, Real, Imaginary, Real and Imaginary, SWR, Power.

Data Points: 1601 maximum. Data points can be switched to a value of 801, 401, 201, 101 or 51 points without recalibration (if 1601 points were used in the calibration). In addition, the system accepts an arbitrary set of N discrete data points where:

$2 < N < 1601$. CW mode permits selection of a single data point without recalibration.

Reference Delay: Can be entered in time or in distance (when the dielectric constant is entered). Automatic reference delay feature adds the correct electrical length compensation at the push of a button. Software compensation for the electrical length difference between reference and test is always accurate and stable since measurement frequencies are always synthesized. In addition, The system compensates reference phase delay for dispersive transmission media, such as waveguide and microstrip.

Markers: Six independent markers can be used to read out measurement data. In delta-reference mode, any one marker can be selected as the reference for the other five. Markers can be directed automatically to the minimum or maximum of a data trace.

Enhanced Markers: Marker search for a level or bandwidth, displaying an active marker for each channel, and discrete or continuous (interpolated) markers.

Marker Sweep: Sweeps upward in frequency between any two markers. Recalibration is not required during the marker sweep.

Limit Lines: Either single or segmented limit lines can be displayed. Two limit lines are available for each trace.

Single Limit Readouts: Interpolation algorithm determines the exact intersection frequencies of test data and limit lines.

Segmented Limits: A total of 20 segments (10 upper and 10 lower) can be generated per data trace. Complete segmented traces can be offset in both frequency and amplitude.

Test Limits: Both single and segmented limits can be used for PASS/FAIL testing. The active channel's PASS or FAIL status is indicated on CRT after each sweep. In addition, PASS/FAIL status is output through the rear panel I/O connector as selectable TTL levels (PASS=0V, FAIL=+5V or PASS=+5V, FAIL=0V).

Tune Mode: Tune Mode optimizes sweep speed in tuning applications by updating forward S-parameters more frequently than reverse ones. This mode allows the user to select the ratio of forward sweeps to reverse sweeps after a full 12-term calibration. The ratio of forward sweeps to reverse sweeps can be set anywhere between 1:1 to 10,000:1.

DISPLAY CAPABILITIES

Display Channels: Four, each of which can display any S-parameter or user defined parameter in any format with up to two traces per channel for a maximum of eight traces simultaneously. A single channel, two channels (1 and 3, or 2 and 4), or all four channels can be displayed simultaneously. Channels 1 and 3, or channels 2 and 4 can be overlaid.

LCD: Color, 8.5" diagonal.

Trace Color: The color of display traces, memory, text, markers and limit lines are all user definable.

Trace Overlay: Displays two traces on the active channel's graticule simultaneously. The overlaid trace is displayed in yellow and the primary trace is displayed in red.

Trace Memory: A separate memory for each channel can be used to store measurement data for later display or subtraction, addition, multiplication or division with current measurement data.

Scale Resolution (minimum):

Log Magnitude: 0.001 dB/div	Linear Magnitude: 1 pU
Phase: 0.01°	Group Delay: 0.001 ps
Time: 0.001 ms	Distance: 0.1 μm
SWR: 1 pU	Power: 0.05 dB
Autoscale: Automatically sets Resolution and Offset to fully display measurement data.	

Reference Position: Can be set at any graticule line.

Annotation: Type of measurement, vertical and horizontal scale resolution, start/stop or center/span frequencies, and reference position.

Blank Frequency Information: Blanking function removes all references to displayed frequencies on the CRT. Frequency blanking can only be restored through a system reset or GPIB command.

MEASUREMENT ENHANCEMENT

Data Averaging: Averaging of 1 to 4096 averages can be selected. Averaging can be toggled on/off with front-panel button. A front-panel button turns data averaging on/off, and a front panel LED indicates when averaging is active.

Video IF Bandwidth: Front panel button selects four levels of video IF bandwidth. MAXIMUM (10 kHz), NORMAL (1 kHz), REDUCED (100 Hz) and MINIMUM (10 Hz).

Trace Smoothing: Functions similarly to Data Averaging but computes an average over a percentage range of the data trace. The percentage of trace to be smoothed can be selected from 0 to 20% of trace. Front-panel button turns smoothing on/off, and front-panel LED indicates when smoothing is active.

SOURCE CONTROL

Frequency Resolution: 1 kHz (1 Hz standard on RF units and optional on Microwave units—Option 10A)

Source Power Level: The source power (dBm) may be set from the 37200B front panel menu or via GPIB. Port 1 power level is settable from +10 dB above to -15 dB below rated power (+20 dB above to -12 dB below rated power for 37269B) with 0.05 dB resolution. Source power ABOVE 0 dB control is allowed but not guaranteed.

Power Accuracy: ±0.5 dB at 2 GHz at default power.

Level Test Port Power: The power, at all sweep frequencies, is leveled to within ±1.5 dB (0.0225 to 13.5 GHz), ±2.0 dB (13.5 to 20 GHz), and ±3.0 dB (20 to 40 GHz).

Power Meter Correction: The 37200B offers a user-selectable feature that corrects for test port power variations and slope (on Port 1) using an external power meter. Power meter correction is available at a user-selectable power level, if it is within the power adjustment range of the internal source. Once the test port power has been flattened, its level may be changed within the remaining power adjustment range of the signal source.

Dual Source Control Capability: Dual Source Control capability allows a user to independently control the frequencies of two sources and the receiver without the need for an external controller. The frequency ranges and output powers of the two sources may be specified. A frequency sweep may be comprised of up to five separate bands, each with independent source and receiver settings, for convenient testing of frequency translation devices such as mixers. Up to five sub-bands may be tested in one sweep. This feature enables users to easily test mixers, up/down converters, multipliers, and other frequency conversion devices.

Source #1: The 37200B's internal source, or any of the family of 68XXXB, 69XXXA, or 6700B synthesizers.

Source #2: Any of the family of 68XXXB, 69XXXA, or 6700B synthesizers.

Sweep Type: Linear, CW, Marker, or N-Discrete point sweep.

SOURCE PURITY

Specifications apply for all models at maximum rated power.

Harmonic and Harmonic Related: 35 dBc, (standard)

Nonharmonics: 35 dBc

Phase Noise:

>60 dBc/Hz at 10 kHz offset and 20 GHz center frequency

SOURCE FREQUENCY ACCURACY

Standard Time Base:

Aging: <1 x 10⁻⁶/day

Stability: <1 x 10⁻⁶ over +15°C to +50°C range

High Stability Time Base (Option 10A):

Aging: <1 x 10⁻⁹/day

Stability: <5 x 10⁻⁹ over 0° to +55°C range

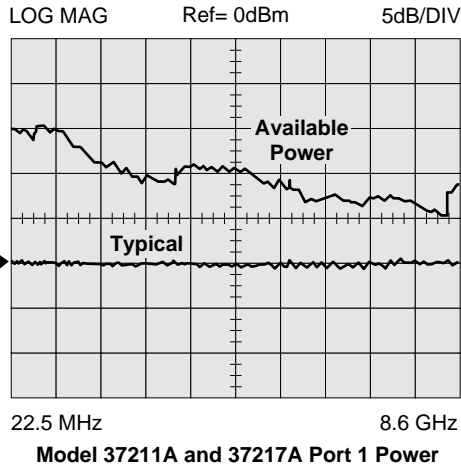

POWER RANGE

Model	Rated Power (dBm)	Minimum Power (dBm)	Resolution (dB)
37211B	0	-15	0.05
37217B	0	-15	0.05
37225B	0	-15	0.05
37247B	0	-15	0.05
37269B	-15	-27	0.05

POWER FLATNESS

Frequency Range (GHz)	Flatness (dB)
0.0225 to 13.5	±1.5
13.5 to 20	±2
20 to 40	±3

GROUP DELAY CHARACTERISTICS

Group Delay is measured by computing the phase change in degrees across a frequency step by applying the formula:

$$\tau_g = -1/360 \, d\phi/df$$

Aperture: Defined as the frequency span over which the phase change is computed at a given frequency point. The aperture can be changed without recalibration. The minimum aperture is the frequency range divided by the number of points in calibration and can be increased to 20% of the frequency range without recalibration. The frequency width of the aperture and the percent of the frequency range are displayed automatically.

Range: The maximum delay range is limited to measuring no more than +180° of phase change within the aperture set by the number of frequency points. A frequency step size of 100 kHz corresponds to 10 ms.

Measurement Repeatability (sweep to sweep): For continuous measurement of a through connection, RSS fluctuations due to phase and FM noise are:

$$\frac{1.41 [(Phase Noise in deg)^2 + (\tau_g \times Residual FM Noise in Hz)^2]^{0.5}}{360 (Aperture in Hz)}$$

Accuracy:

$$Error \, in \, \tau_g = \frac{Error \, in \, phase \, (deg)}{360} + \frac{[(\tau_g \times Aperture \, Freq. \, Error \, (Hz)]}{Aperture \, (Hz)}$$

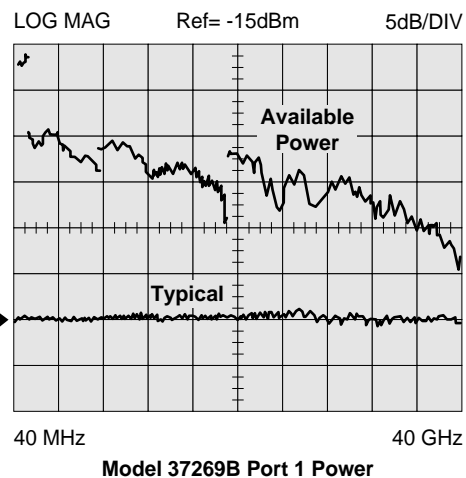
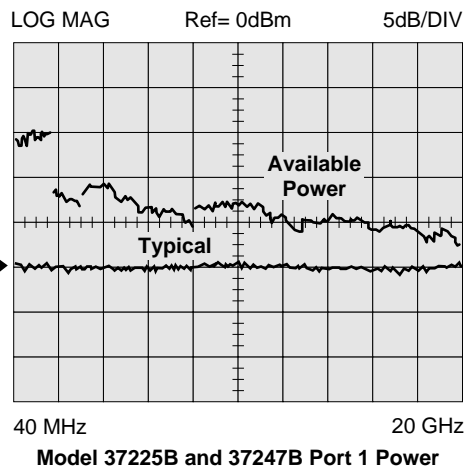

VECTOR ERROR CORRECTION

There are three methods of calibration:

- 1) Open-Short-Load (OSL):** This calibration method uses short circuits, open circuits, and terminations (fixed or sliding)
- 2) Offset-Short (waveguide):** This calibration method uses short circuits, and terminations.
- 3) LRL/LRM:** The Line-Reflect-Line (LRL) or Line-Reflect-Match (LRM) calibration uses transmission lines and a reflective device or termination (LRM).
- 4) TRM:** The Thru-Reflect-Match calibration uses short circuits and fixed termination.

There are four vector error correction models available:

- 1) Full 12-Term**
- 2) One Path/Two Port**
- 3) Frequency Response (Transmission/Reflection)**
- 4) Reflection Only**

Full 12-Term can always be used, if desired, since all 37200B series models automatically reverse the test signal. Front-panel display indicates the type of calibration stored in memory. Front-panel button selects whether calibration is to be applied, and an LED lights when error correction data are being applied.

Calibration Sequence: Prompts the user to connect the appropriate calibration standard to Port 1 and/or Port 2. Calibration standards may be measured simultaneously or one at a time.

Calibration Standards: For coaxial calibrations the user selects SMA, GPC-3.5, GPC-7, Type N, 2.4 mm, TNC, K Connector or special type from a calibration menu. Use of fixed or sliding loads can be selected for each connector type. User defined calibration standards allow for entry of open capacitance, Load and Short inductances, load impedance, and reflection standard offset lengths.

Reference Impedance: Modify the reference impedance of the measurement to other than 50 Ω (but not 0).

LRL/LRM Calibration Capability: The LRL calibration technique uses the characteristic impedance of a length of transmission line as the calibration standard. A full LRL calibration consists merely of two transmission line measurements, a high reflection measurement, and an isolation measurement. The LRM calibration technique is a variation of the LRL technique that utilizes a precision termination rather than a second length of transmission line. A third optional standard, either Line or Match, may be measured in order to extend the frequency range of the calibration. This extended calibration range is achieved by mathematically concatenating either two LRL, two LRM, or one LRL and one LRM calibration(s). Using these techniques, full 12-term error correction can be performed on the 37200B VNA.

Adapter Removal Calibration: Built-in Adapter Removal application software accurately characterizes and "removes" any adapter used during calibration that will not be used for subsequent device measurements. This technique allows for accurate measurement of non-insertable devices.

Dispersion Compensation: Selectable as Coaxial (non-dispersive), Waveguide, or Microstrip (dispersive).

Reference Plane: Selectable as Middle of line 1 or Ends of line 1.

Corrected Impedance: Determined by Calibration Standards.

HARD COPY

Printer: Menu selects full screen, graphical, tabular data, and printer type. The number of data points of tabular data can be selected as well as data at markers only. Compatible with the 2225C InkJet, HP QuietJet, HP 310/320 DeskJet, HP 500 DeskJet, HP 560C (b/w only), HP LaserJet II, III, and IV Series, and Epson 9 pin compatible printers with Parallel (Centronics) interfaces.

GPIB Plotter: The 37200B is compatible with HP Models 7440A, 7470A, 7475A, and 7550A (in standard mode) and Tektronix Model HC100 plotters. Menu selects plotting of full or user-selected portions of graphical data. Plotter is connected to the dedicated GPIB bus.

Performance: After selecting the Start Print button, front panel operation and measurement capability is restored to the user within 2 seconds.

STORAGE

Internal Memory: Ten front panel states (no calibration) can be stored and recalled from non-volatile memory locations. The current front panel setup is automatically stored in non-volatile memory at instrument power-down. When power is applied, the instrument returns to its last front panel setup.

Internal Hard Disk Drive: 80 MB min., used to store and recall measurement and calibration data and front-panel setups. All files are MS-DOS[®] compatible. File names can be 1 to 8 characters long, and must begin with a character, not a number. Extensions are automatically assigned.

External SCSI Interface: Option 4 deletes the internal hard disk drive, and adds a SCSI Interface connector to the rear panel for connecting a SCSI-2 formatted hard disk drive.

Internal Floppy Disk Drive: A 3.5-inch diskette drive with 1.44 Mbytes formatted capacity is used to load measurement programs and to store and recall measurement and calibration data and front-panel setups. Measurement data can be stored in text or S2P format. All files are MS-DOS compatible. File names can be 1 to 8 characters long, must begin with a character, not a number. Extensions are automatically assigned.

Measurement Data: 102.8 kbytes per 1601 point S-parameter data file.

Calibration Data: 187.3 kbytes per 1601 point S-parameter data file (12-term cal plus setup).

Trace Memory File: 12.8 kbytes per 1601 point channel.

GPIB

GPIB INTERFACES – 2 Ports

System GPIB (IEEE-488.2): Connects to an external controller for use in remote programming of the network analyzer. Address can be set from the front panel and can range from 1 to 30.

Interface Function Codes: SH1, AH1, T6, TE0, L4, LE0, SR1, RL1, PP1, DT1, DC0, C0.

Dedicated GPIB: Connects to external peripherals for network analyzer controlled operations (e.g. GPIB plotters, frequency counters, frequency synthesizers and power meters).

GPIB Data Transfer Formats: ASCII, 32-bit floating point, or 64-bit floating point. 32-bit and 64-bit floating point data can be transferred with LSB or MSB first.

GPIB DATA COLLECTION SUMMARY

This section summarizes typical data collection times for automated measurements using the 37200B's IEEE 488.2 GPIB bus.

Throughput measurements for both tables were made as follows: start the timer, trigger a sweep, wait for a full sweep, transfer data across the GPIB and stop the timer. Data throughput times are shown separately for measurements made without calibration and with full two-port, 12-term calibration.

Data Transfer Speed (with or without cal): 62 kbyte/sec

Measurement conditions: 40 MHz to 20 GHz sweep, single channel, log magnitude display, 10 kHz IF bandwidth, and output final data.

Throughput Times (ms) without Correction (typical)

Data Format	3 Points*	101 Points	401 Points	1601 Points
32 Bit	270	650	1400	3600
64 Bit	300	680	1450	4000
ASCII	300	800	1700	5000

*3 data point sweeps taken at 2, 4, and 6 GHz

Throughput Times (ms) with 12-term Correction (typical)

Data Format	3 Points*	101 Points	401 Points	1601 Points
32 Bit	340	1200	2600	7800
64 Bit	350	1200	2700	8300
ASCII	350	1280	3000	9300

*3 data point sweeps taken at 2, 4, and 6 GHz

GENERAL

37200B Front Panel Connectors and Controls:

Keyboard Input: An IBM-AT compatible keyboard can be connected to the front panel for navigating through front panel menus, annotation of data files and display labels, printing displays and pausing instrument sweeps.

Test Ports: Universal/K, male, connectors are standard. For other configurations check Option 7. For additional configurations check Test Port Converters.

37200B Rear Panel Connectors and Controls:

PRINTER OUT: Centronics interface for an external printer.

VGA OUT: Provides VGA output of 37200B video display.

10 MHz REF IN: Connects to external reference frequency standard, 10 MHz, +5 to -5 dBm, 50 Ω, BNC female.

10 MHz REF OUT: Connects to internal reference frequency standard, 10 MHz, 0 dBm, 50 Ω, BNC female.

EXT ANALOG OUT: -10V to +10V with 5 mV resolution, varying in proportion to user-selected data (e.g., frequency, amplitude). BNC female.

EXT ANALOG IN: ±50 volt input for displaying external signals on the CRT in Diagnostics mode. BNC female.

LINE SELECTION: Power supply automatically senses 100V, 120V, 220V or 240V lines.

EXTERNAL TRIGGER: External TTL triggering for 37200B measurement. 10 kΩ input impedance, BNC female.

REFERENCE EXTENSION: Provides access to the a₁ sampler; K Connector, female (Option 11).

EXTERNAL SCSI: Provides SCSI-2 connector for connection of an external SCSI hard disk drive (Option 4).

EXTERNAL I/O: 25-pin DSUB connector.

LIMITS PASS/FAIL: Selectable TTL levels (Pass=0V, Fail=+5V or Pass=+5V, Fail=0V. Additionally, 0 volts (all displayed channels pass) or +5V (any one of 4 displayed channels fail) output pass/fail status (1 line).

EXTERNAL TRIGGER: External triggering for 37XXX measurement, ±1V trigger. 10 kΩ input impedance. BNC female.

EXT ANALOG OUT: -10V to +10V with 5 mV resolution, varying in proportion to user-selected data (e.g., frequency, amplitude), BNC female.

Power Requirements: 85-240 volts, 48-63 Hz, 540 VA maximum

Dimensions: 267 H x 432 W x 585 D mm
(10.5 H x 17 W x 23 D in.)

Weight: 27 kg (60 lb)-(2-man lift required).

ENVIRONMENTAL

Storage Temperature Range: -40°C to +75°C

Operating Temperature Range: 0°C to +50°C

Relative Humidity: 5% to 95 % at +40°C

EMI: Meets the emissions and immunity requirements of EN55011/1991 Class A/CISPR-11 Class A EN50082-1/1993

IEC 801-2/1984 (4 kV CD, 8 kV AD)

IEC 1000-4-3/1995 (3 V/m, 80-1000 MHz)

IEC 801-4/1988 (500V SL, 1000V PL)

IEC 1000-4-5/1995 (2 kV L-E, 1 kV L-L)

MEASUREMENT UNCERTAINTY

The following graphs give measurement uncertainty after 12-term vector error correction. The errors are worst case contributions of residual directivity, load and source match, frequency response, isolation, network analyzer dynamic accuracy, and connector repeatability. In preparing the following graphs, 10 Hz IF bandwidth and averaging of 512 points were used. Changes in the IF bandwidth or averaging can result in variations at low levels.

Models 37211B and 37217B (GPC-7 Connectors)

Reflection Measurements:

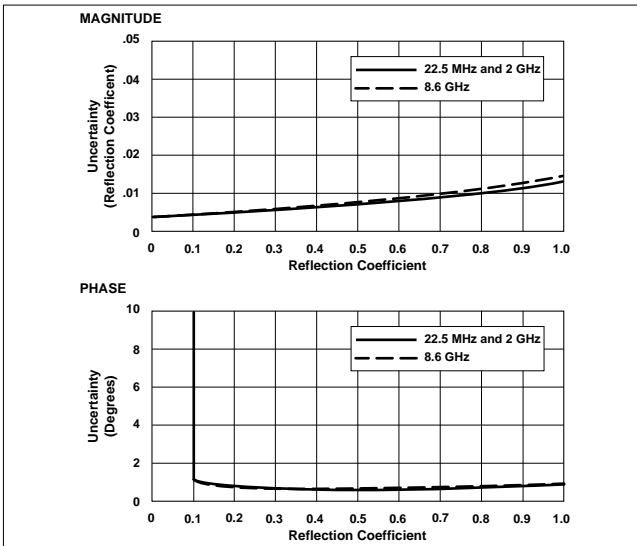

Transmission Measurements:

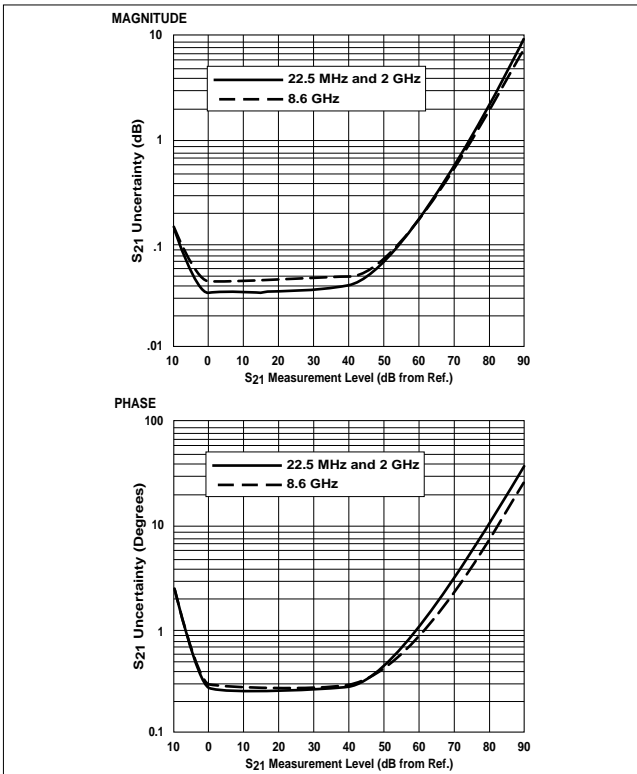

Models 37211B and 37217B (N-Type Connectors)

Reflection Measurements:

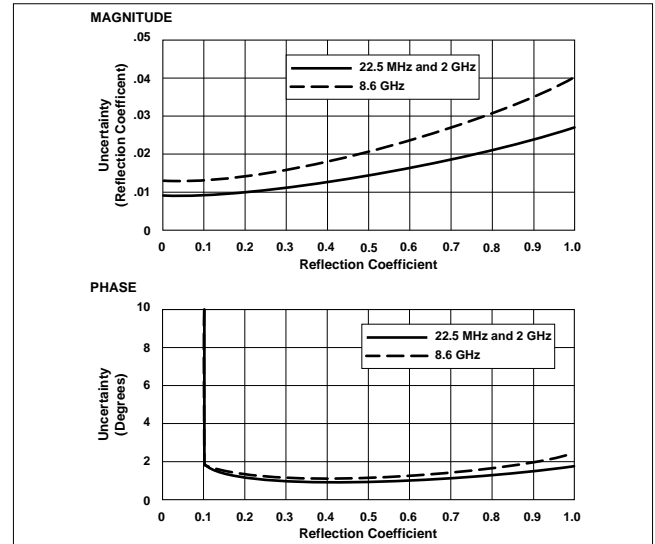

Transmission Measurements:

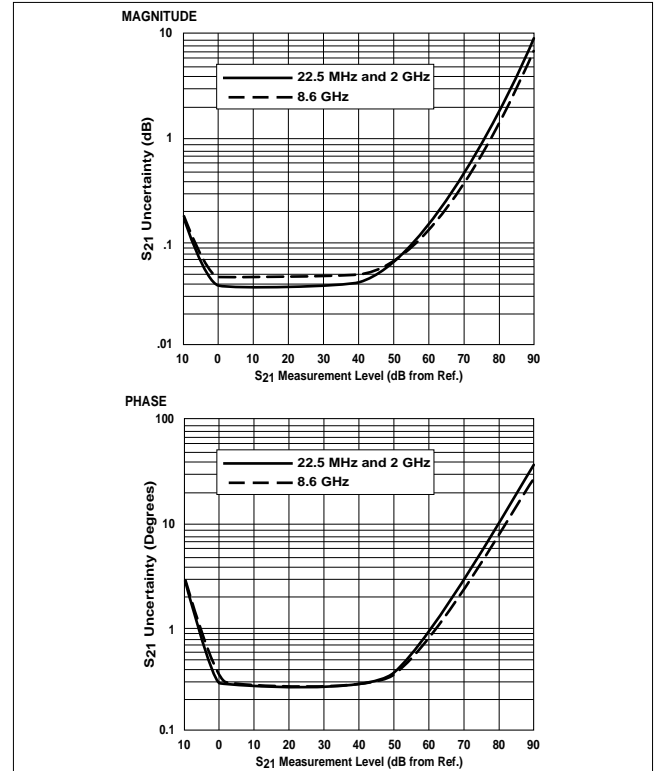

Model 37211B and 37217B (3.5 mm-Connectors)

Reflection Measurements:

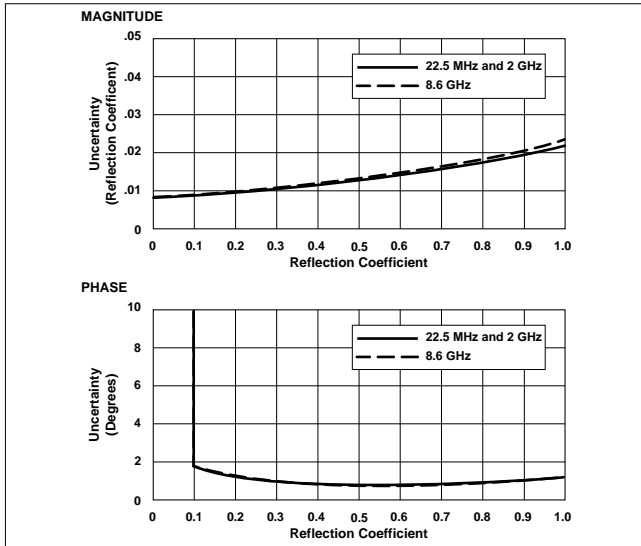

Models 37211B and 37217B (K-Connectors)

Reflection Measurements:

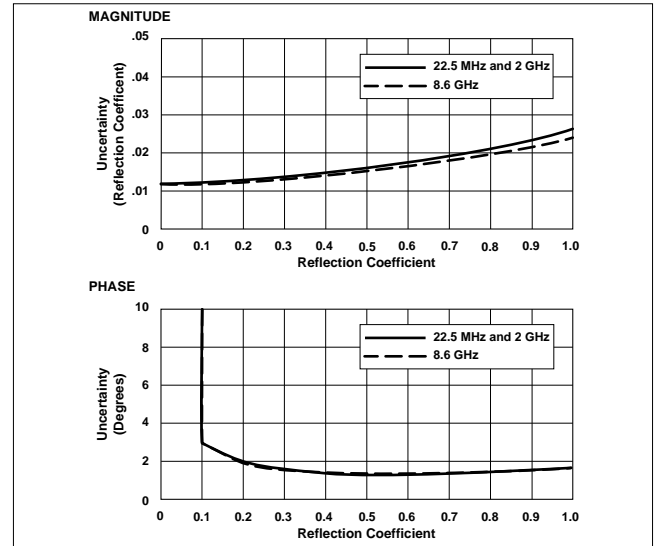

Transmission Measurements:

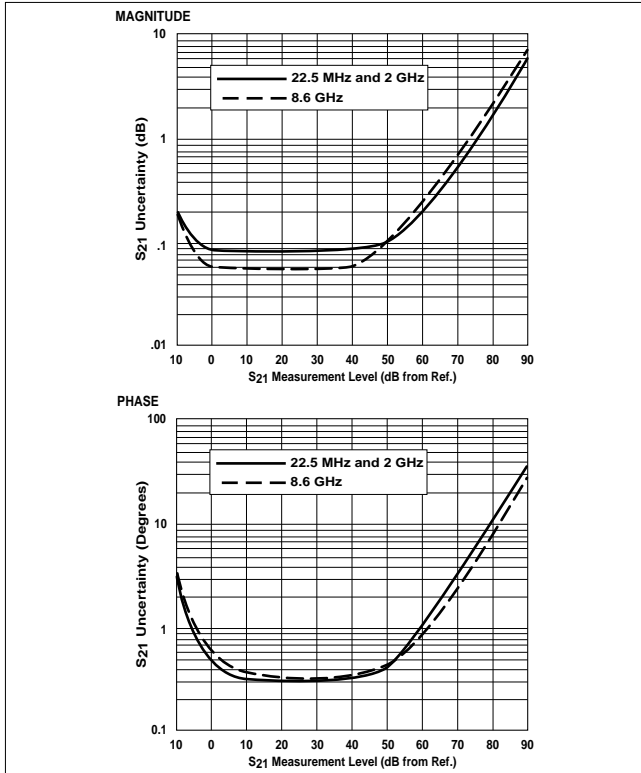

Transmission Measurements:

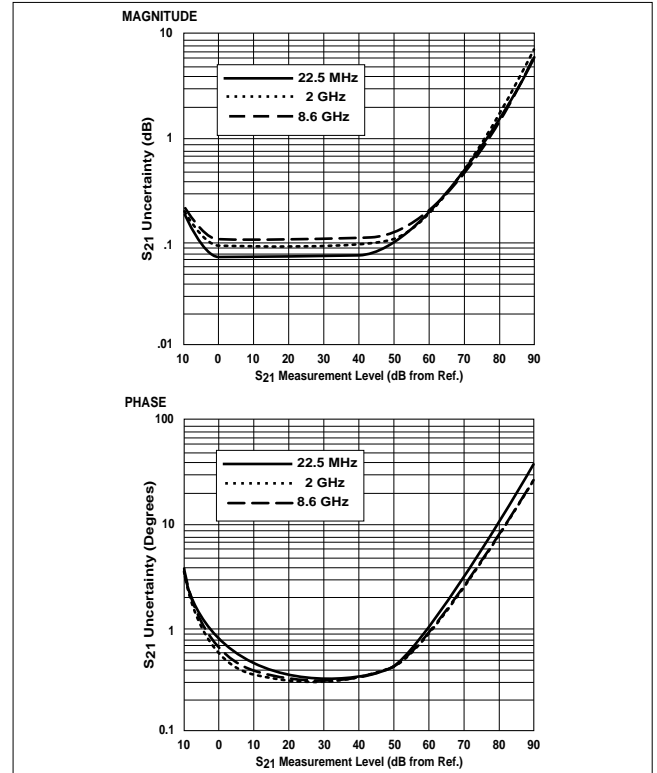

**Model 37217B Universal Test Fixture (Model 3680K),
Microstrip LRL Calibration (Model 36804-15, 15 mil
calibration kit)**

Reflection Measurements:

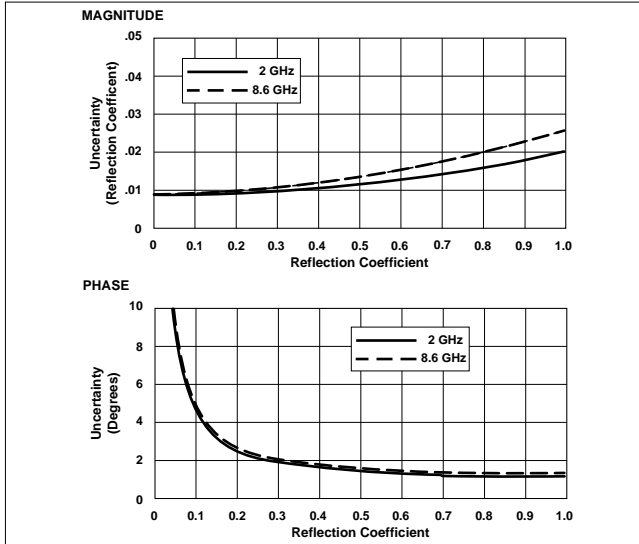

Transmission Measurements:

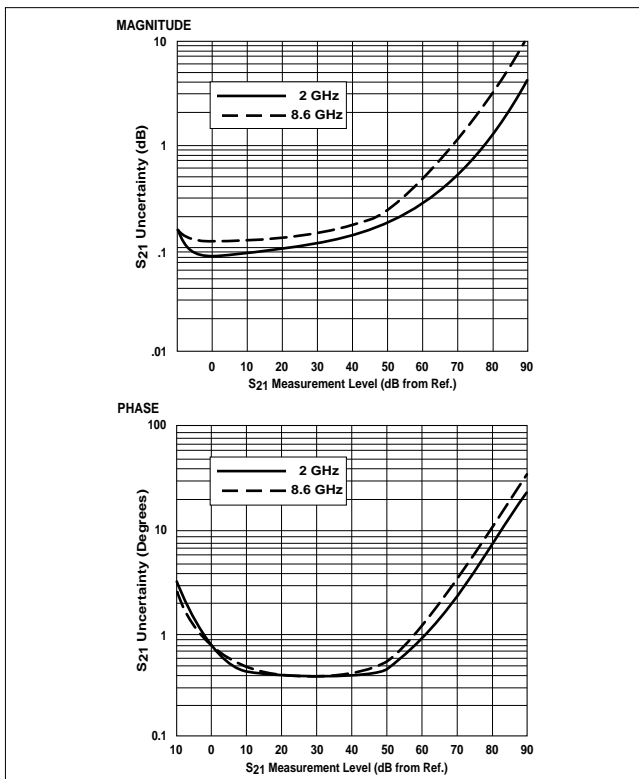

**Model 37217B Universal Test Fixture (Model 3680K),
Microstrip LRL Calibration (Model 36804-15, 15 mil
calibration kit)**

LRL Performance (typical):

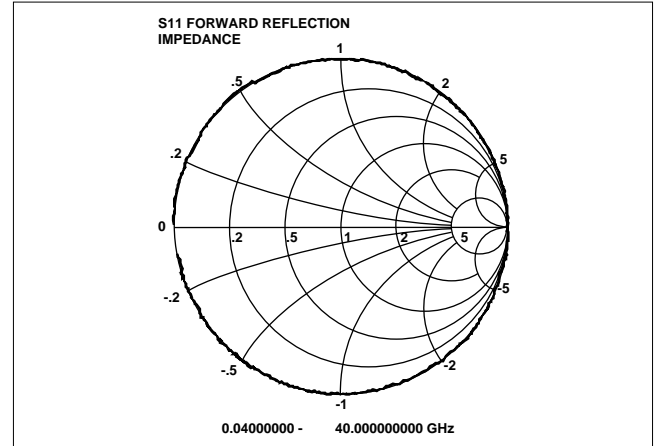

Measurement Setup:

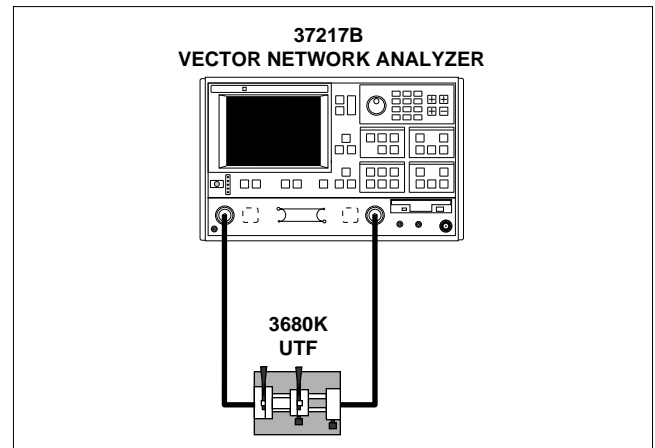

Models 37225B and 37247B (GPC-7 Connectors)

Reflection Measurements:

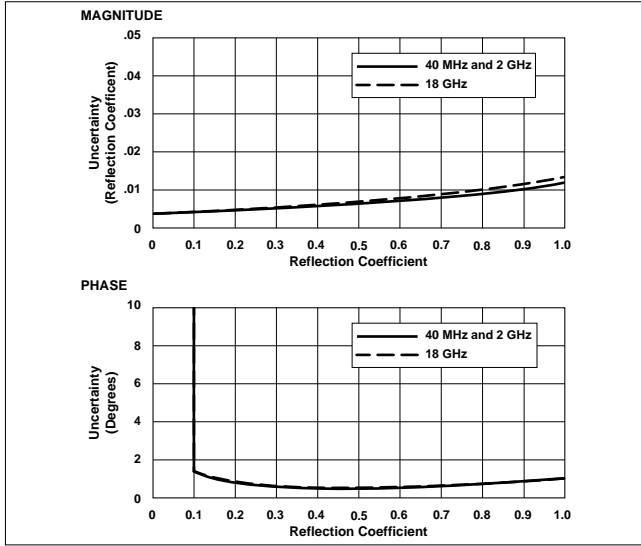

Models 37225B and 37247B (N-Type Connectors)

Reflection Measurements:

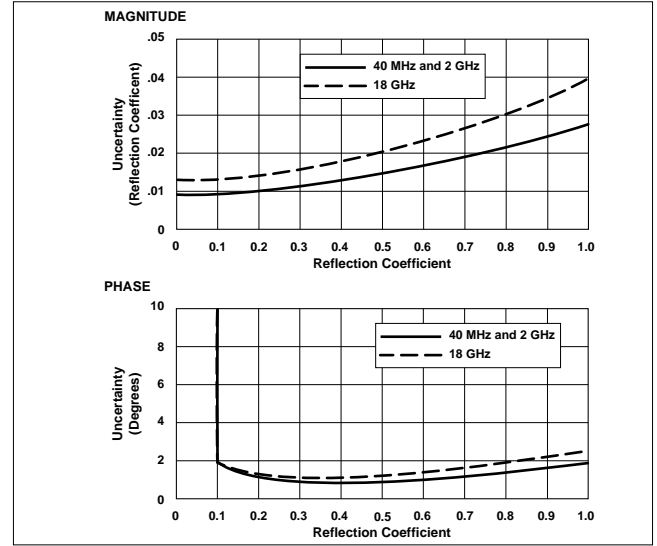

Transmission Measurements:

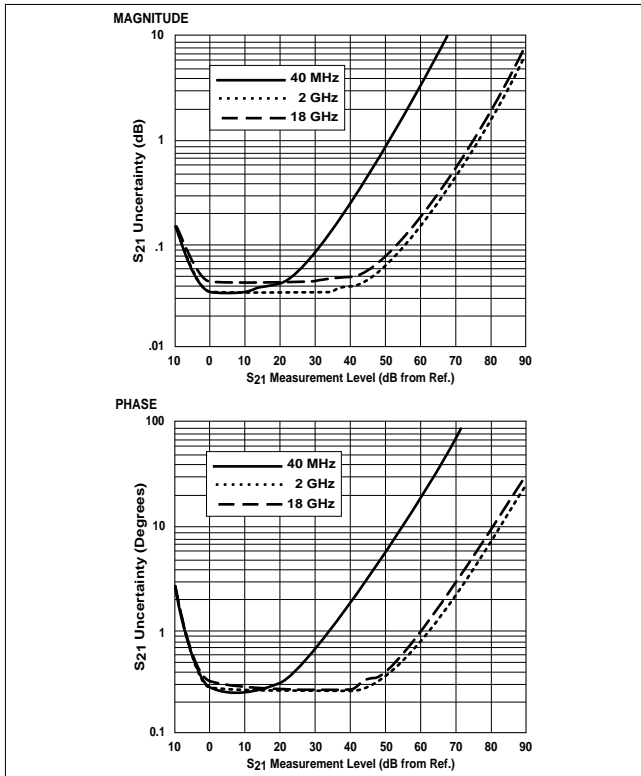

Transmission Measurements:

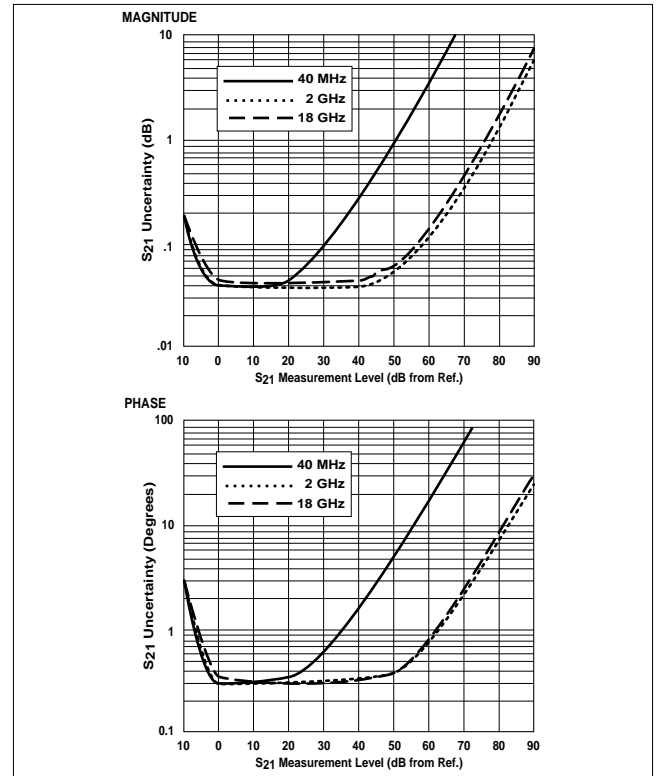

Models 37225B and 37247B (3.5 mm Connectors)

Reflection Measurements:

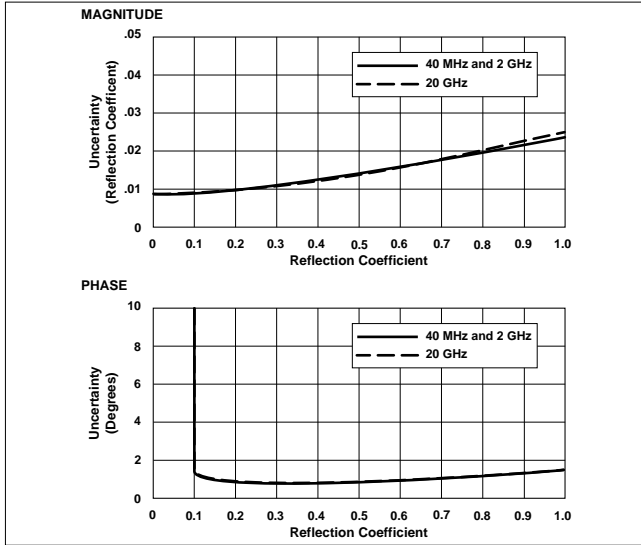

Models 37225B and 37247B (K-Connectors)

Reflection Measurements:

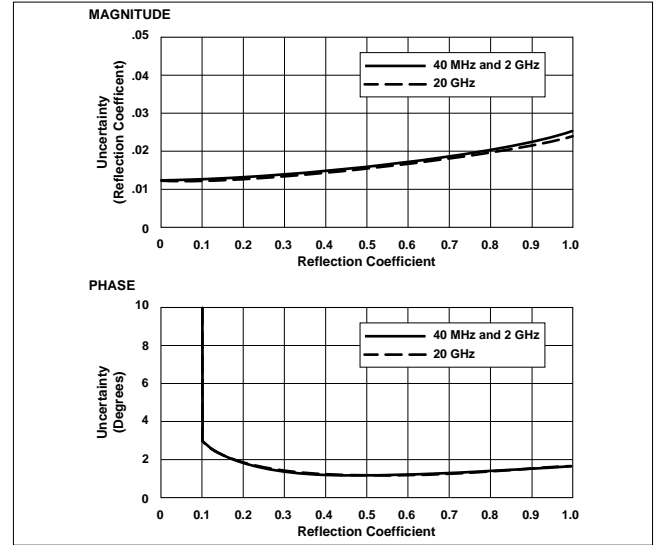

Transmission Measurements:

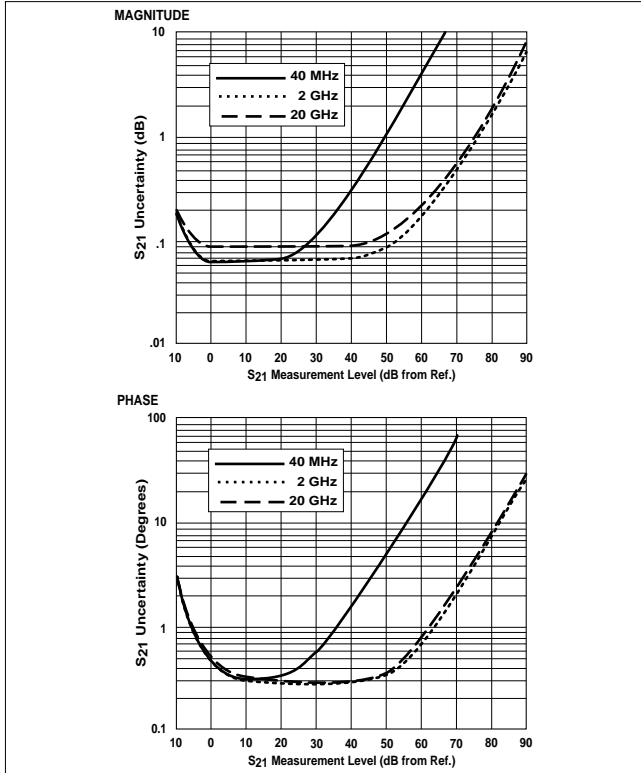

Transmission Measurements:

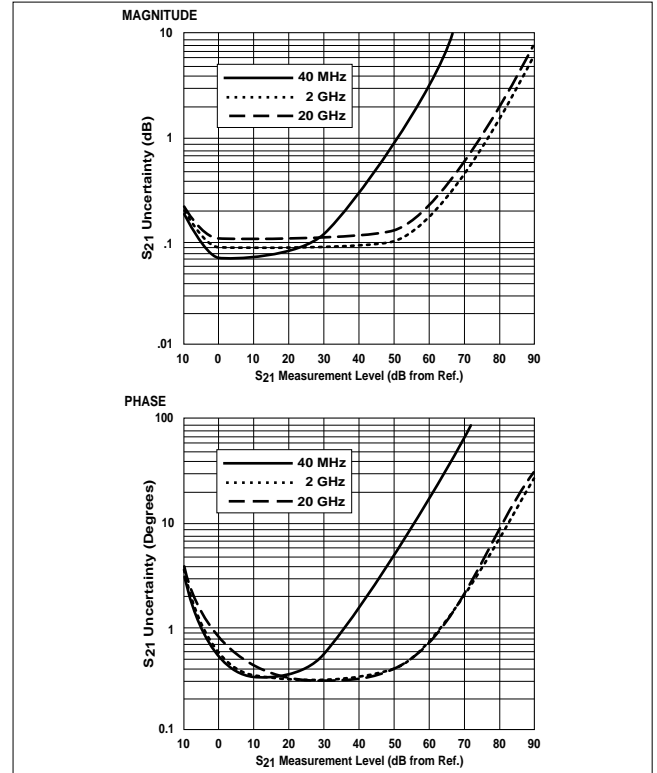

Model 37269B (K-Connectors)

Reflection Measurements:

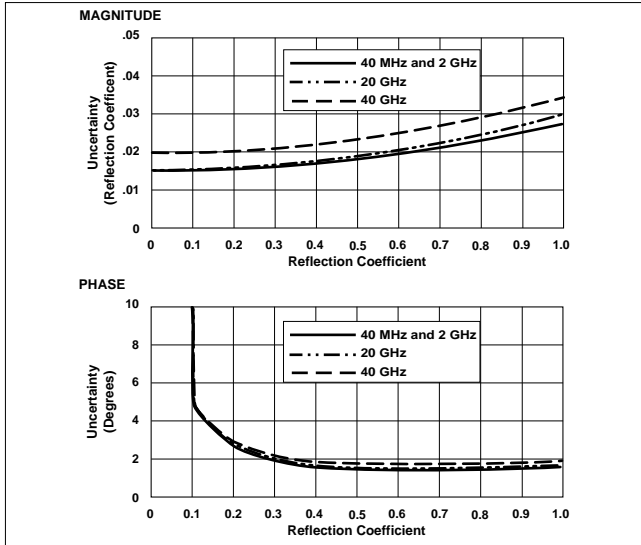

Transmission Measurements:

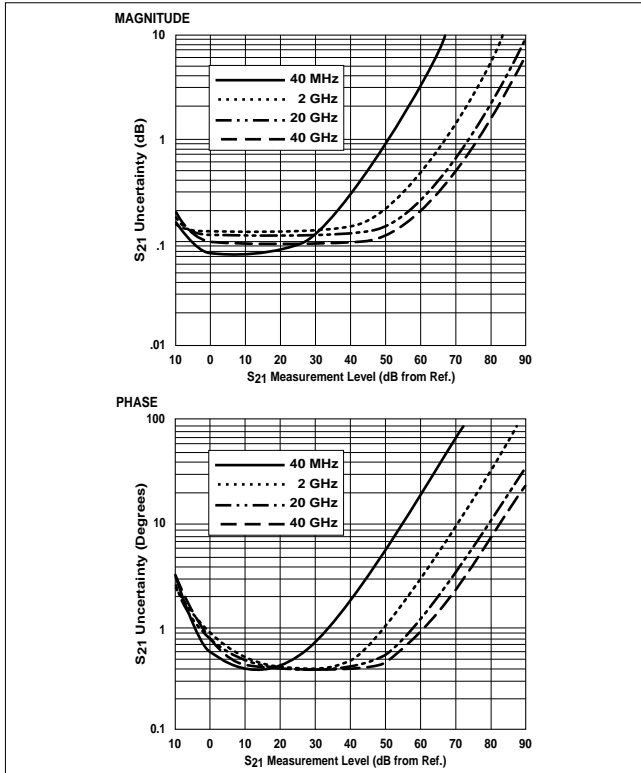

**Model 37269B Universal Test Fixture (Model 3680K),
Microstrip LRL Calibration (Model 36804-10, 10 mil
calibration kit)**

Reflection Measurements:

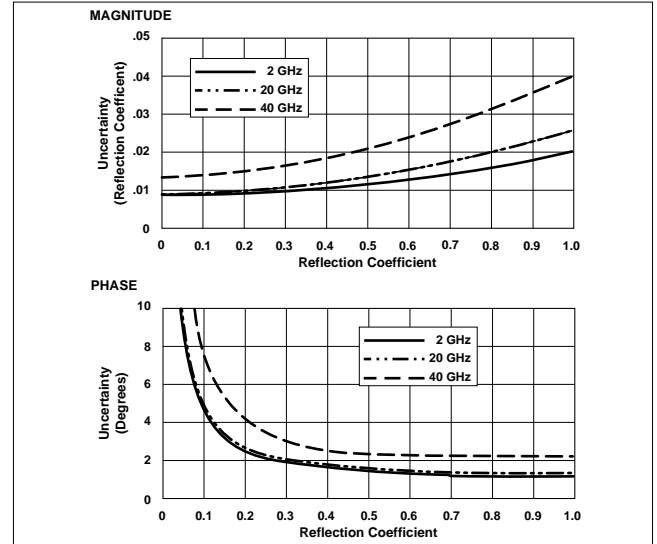

Transmission Measurements:

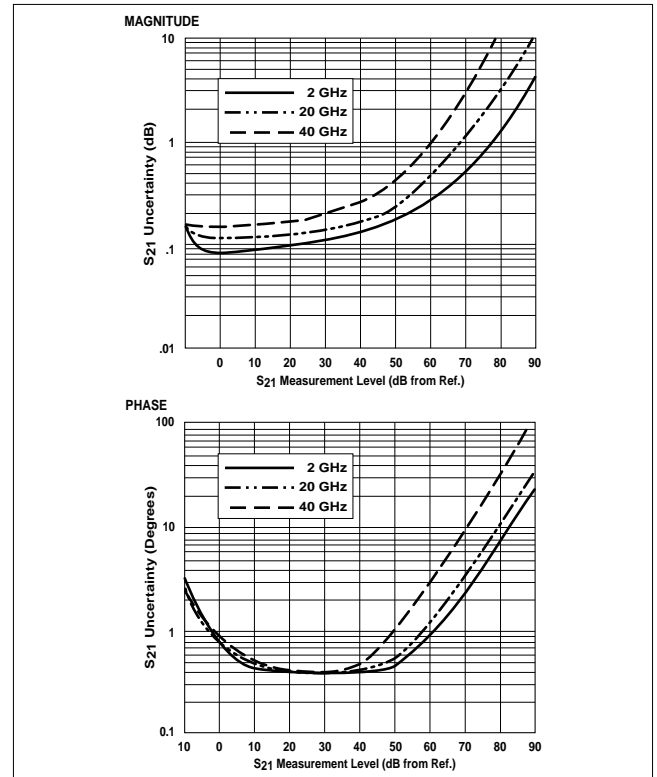

**Model 37269B Universal Test Fixture (Model 3680K),
Microstrip LRL Calibration (Model 36804-10, 10 mil
calibration kit)**

LRL Performance (typical):

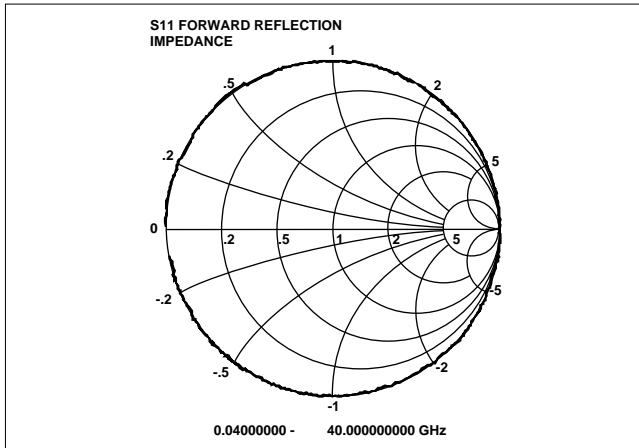

Measurement Setup:

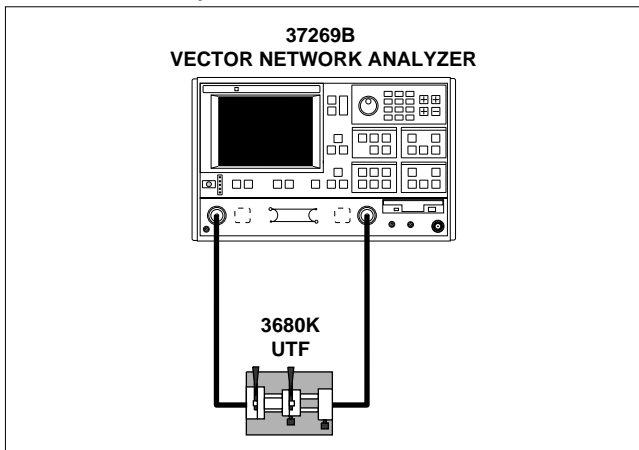

**HIGH SPEED TIME (DISTANCE) DOMAIN
MEASUREMENT CAPABILITY (OPTION 2A)**

Option 2A, High Speed Time (Distance) Domain software allows the conversion of reflection or transmission measurements from the frequency domain to the time domain. Measured S-parameter data is converted to the time domain by application of a Fast Fourier Transform (FFT) using the Chirp Z-Transform technique. Prior to conversion any one of several selectable windowing functions may be applied. Once the data is converted to the time domain, a gating function may be applied to select the data of interest. The processed data may then be displayed in the time domain with display start and stop times selected by the user or in the distance domain with display start and stop distance selected by the user. The data may also be converted back to the frequency domain with a time gate to view the frequency response of the gated data.

Lowpass Mode: This mode displays a response equivalent to the classic "TDR" (Time Domain Reflectometer) response of the device under test. Lowpass response may be displayed in either the impulse or step mode. This type of processing requires a sweep over a harmonic series of frequencies and an extrapolated or user-entered DC value.

Bandpass Mode: This mode displays a response equivalent to the time response of the device under test to a band limited impulse. This type of processing may be used with any arbitrary frequency sweep range, limited only by the test set range or device under test response.

Phasor Impulse Mode: This mode displays a response similar to the Lowpass impulse response, using data taken over an arbitrary (band limited) sweep range. Detailed information, similar to that contained in the lowpass impulse response may be used to identify the nature of impedance discontinuities in the device under test. Now, with Phasor Impulse, it is possible to characterize complex impedances on band-limited devices.

Windowing: Any one of four window functions may be applied to the initial frequency data, to counteract the effects of processing data with a finite bandwidth. These windows provide a range of tradeoffs of main lobe width versus sidelobe level (ringing). The general type of function used is the Blackman-Harris window with the number of terms being varied from one to four. Typical performance follows:

Type of Window (Number of Terms)	First Side Lobe Relative to Peak	Impulse Width ¹
Rectangular (1)	-13 dB	1.2W
Nominal-Hamming (2)	-43 dB	1.8W
Low Side Lobe, Blackman-Harris (3)	-67 dB	2.1W
Minimum Side Lobe, Blackman-Harris (4)	-92 dB	2.7W

¹W(Bin Width) = 1/2Δf sweep width.

Example. When Δf = 40 MHz to 40 GHz, W = 12.5 ps

Gating: A selective gating function may be applied to the time domain data to remove unwanted responses, either in a pass-band or reject-band (mask). This gating function may be chosen as the convolution of any of the above window types with a rectangular gate of user defined position and width. The gate may be specified by entering start and stop times or center and span. The gated data may be displayed in the time domain, or converted back to the frequency domain.

Time Domain Display: Data processed to time domain may be displayed as a function of time or as a function of distance, provided the dielectric constant of the transmission media is entered correctly. In the case of dispersive media such as waveguide or microstrip, the true distance to a discontinuity is displayed in the distance mode. The time display may be set to any arbitrary range by specifying either the start and stop times or the center time and span. The unaliased (non-repeating) time range is given by the formula:

$$\text{Unaliased Range (ns)} = \frac{\text{Number of Frequency Data Points}}{\text{Frequency Sweep Range (GHz)}}$$

The resolution is given by the formula:

$$\text{Main Lobe Width (null-null) in ns} = \frac{kW}{\text{Freq. Sweep Range (GHz)}}$$

where kW is two times the number of window terms
(for example, four for a two-term window)

For a 40 GHz sweep range with 1601 data points, the unaliased range is 40.025 nanoseconds.

Frequency with Time Gate: Data that has been converted to time domain and selected by the application of gating function may be converted back to the frequency domain. This allows the display of the frequency response of a single element contained in the device under test. Frequency response accuracy is a function of window and gate type, and gate width. For a full reflection, minimum gate and window accuracy is within 0.2 dB of the ungated response over a 40 GHz range.

SYSTEM OPTIONS

OPTION 1, Rack Mounting

Rack mount kit containing a set of track slides (90° tilt capability), mounting ears, and front panel handles to let the instrument be mounted in a standard 19-inch equipment rack.

OPTION 1A, Rack Mounting

Rack mounting kit containing a set of mounting ears and hardware to permanently mount instrument in a standard 19-inch equipment rack.

OPTION 2, High Speed Time (Distance) Domain Measurement Capability

OPTION 4, External SCSI-2 Hard Disk Drive Compatibility

Provides SCSI-2 rear panel connector for connection of an external SCSI HDD. Remove internal HDD.

OPTION 7A/N/NF/S, Universal Test Port Configuration

Replaces Universal/K Connector (standard) with:

- 7A – Universal/GPC-7
- 7N – Universal/N, male
- 7NF – Universal/N, female
- 7S – Universal/3.5 mm, male

OPTION 10A, High Stability Time Base and 1 Hz Resolution

Replaces the standard temperature compensated crystal oscillator (with a temperature stability of 1ppm over a 0 to 55°C range) with an ovenized crystal oscillator (aging stability of 1 x 10⁻⁹/day and temperature stability 5 x 10⁻⁹ over 0 to 55°C range). Also adds 1 Hz Resolution. (Standard on 37211B and 37217B)

OPTION 11, Reference Loop Extension Cables

Provides access to the a₁ sampler RF input, allowing the user direct access to this channel.

UPGRADE OPTIONS*

ND42844 – Upgrade 37211B to 37311A

ND42845 – Upgrade 37217B to 37317A

ND42846 – Upgrade 37225B to 37325A

ND42847 – Upgrade 37247B to 37347A

ND42848 – Upgrade 37269B to 37369A

ND42849 – Upgrade 37211B to 37217B

ND42850 – Upgrade 37211B to 37225B

ND42851 – Upgrade 37211B to 37247B

ND42852 – Upgrade 37211B to 37269B

ND42853 – Upgrade 37217B to 37225B

ND42854 – Upgrade 37217B to 37247B

ND42855 – Upgrade 37217B to 37269B

ND42856 – Upgrade 37225B to 37247B

ND42857 – Upgrade 37225B to 37269B

ND42858 – Upgrade 37247B to 37269B

Upgrades for your 37200A, to extend frequency coverage, or to upgrade to the 37300A family are also available. Consult with Anritsu Wiltron for details.

*Upgrades from RF to microwave models maintain 1Hz frequency resolution capability.

ON-SITE SUPPORT

Option ES 31: 3 year on-site repair.

Option ES 37: 3 year on-site verification

Option ES 38: 3 year on-site Mil-Std verification

Option ES 51: 5 year on-site repair.

Extended Service Options

Additional, two year and four year “return to factory” service is available, as an option for 37200B systems and components. Prices and details are available from your Sales Representative or by contacting the factory.

SOFTWARE

2300-217 Logo Editor

2300-218 Power Tools (DLLs)

2300-232 Mixer Measurements

2300-170 MMICAD for Window®

CALIBRATION KITS

Standard

3650 SMA/3.5 mm Calibration Kit

Option 1: Male and Female Sliding Terminations

3651 GPC-7 Calibration Kit

Option 1: Sliding Terminations

3652 K Connector Calibration Kit

Option 1: Male and Female Sliding Terminations

3653 Type N Calibration Kit

Economy (8.6 GHz)

3750 SMA Calibration Kit

3751 GPC-7 Calibration Kit

3753 Type N, 50 Ω , Calibration Kit

3753-75 Type N, 75 Ω , Calibration Kit

T/LRM

36550 3.5 mm Calibration Kit

36552 K Connector Calibration Kit

36553 Type N Calibration Kit

AUTOCAL

36581NNF, N (m) to N (f), 40 MHz to 18 GHz

36581KKF, K (m) to K (f), 40 MHz to 20 GHz

36582KKF, K (m) to K (f), 40 MHz to 40 GHz

36583S, Test Port Cable Converter Set, SMA type

36583L, Test Port Cable Converter Set, 3.5 mm type

36583K, Test Port Cable Converter Set, K type

2300-228, AutoCal Characterization Software

760-208, AutoCal Transit Case

VERIFICATION KITS

3663 Type N Verification Kit

3666 3.5 mm Verification Kit

3667 GPC-7 Verification Kit

3668 K Connector Verification Kit

SEMI-RIGID TEST PORT CABLES

3670A50-1, GPC-7, 1 foot, two required.

3670A50-2, GPC-7, 2 foot.

3670K50-1, K (f)-K (m), 1 foot, two required.

3670K50-2, K (f)-K (m), 2 foot.

3670KF50-1, K (f)-K (f), 1 foot, two required

3670KF50-2, K (f)-K (f), 2 foot.

FLEXIBLE TEST PORT CABLES

3671A50-1 K (f) - GPC-7, 25 in., 2 each.

3671A50-2 K (f) - GPC-7, 38 in.

3671S50-1 K (f) - 3.5 mm (m) and K (f) - 3.5 mm (f), 25 in. each

3671S50-2 K (f) - 3.5 mm, 38 in.

3671K50-1 K (f) - K (m), 25 in., 2 each.

3671K50-2 K (f) - K (m), 38 in.

3671K50-3 K (f) - K (f), and K (f) - K (m), 25 in. each

TEST PORT CONVERTERS

34UA50 Test Port Converter, Universal/GPC-7

34UK50 Test Port Converter, Universal/K Connector, male

34UN50 Test Port Converter, Universal/N, male

34UNF50 Test Port Converter, Universal/N, female

34UQ50 Test Port Converter, Universal/2.4 mm, male

34US50 Test Port Converter, Universal/3.5 mm, male

01-202 Wrench, for changing test set Test Port Converters.

GPIB CABLES

2100-1 GPIB Cable, 1 m (3.3 ft.)

2100-2 GPIB Cable, 2 m (6.6 ft.)

2100-4 GPIB Cable, 4 m (13.2 ft.)

2100-5 GPIB Cable, 0.5 m (1.65 ft.)

ACCESSORIES

2000-660 HP 310 Deskjet Printer, Printer Stand, 1 in. Deskjet Printer Cartridge and Power cord.

2000-661 Extra Printer Cartridge

2000-662 Rechargeable Battery

2000-663 Power Cable, Europe

2000-664 Power Cable, Australia

2000-665 Power Cable, U.K.

2000-666 Power Cable, Japan

2000-667 Power Cable, South Africa

2225-1 Spare Parallel Interface Printer Cable

LRL/LRM-Calibration method of Rhode & Schwartz, Germany.

GPC-7 is a registered trademark of Amphenol Corporation.

K Connector and V Connector are registered trademarks of Wiltron Company.

MS-DOS is a registered trademark of Microsoft Corporation.



Certificate No. 6495

U.S. Sales Centers:

North West (408) 776-8305
North East (201) 227-8999
South West (310) 715-8262
South East (301) 590-0300

Anritsu
Wiltron

Microwave Measurements Division • 490 Jarvis Drive • Morgan Hill, CA 95037-2809
<http://www.anritsuwiltron.com> • FAX (408) 778-0239

International Sales Centers:

Europe 44 (582) 418853
Japan (03) 3446-1111
Canada (613) 828-4090
Asia-Pacific 81 (3) 3440-2770